

High-Speed, High Reliability Serial ATA 3Gb/s Half-Slim SSD (Solid State Drive) with SMART Life Monitor Software SHG2A Series of 1GB to 16GB

Conformity to RoHS Directive

TDK's RS2 SSD Controller with Built-in Power Backup Circuit For Industrial-Use SATA2 Flash Drive Half-Slim SSD

The TDK SHG2A series of SATA II industrial-use Half-Slim SSD (Solid State Drive)* are half the size of conventional 1.8-inch Hard Disk Drives (HDDs), and come in capacities up to 16GB. This series features high-speed data access with an effective reading speed of 95MByte/sec, and has a powerful error-correcting ability that can be extended up to 15bit/sector ECC resulting in excellent data reliability. These Half-Slim drives contain a power backup circuit and an auto data protection function, and have strong system power-off durability. They can be used as built-in Half-Slim SSDs for vehicles and for industrial usage.

Thanks to TDK advanced dispersion writing method, SHG2A series demonstrates the longest storage lifespan in the industry.

The lifespan of these Half-Slim drives can be recognized and drive replacement times can be understood quantitatively in real time using the SMART program available on TDK website. Sufficient data security is achieved using advanced AES 128Bit encryption. By using a combination of the ATA standard security function and TDK's password lock function, it is possible to prevent falsification, leakage, and unauthorized copying of private and confidential information.

* Standards for Half-Slim SSD (Solid State Drive) have been determined by the JEDEC and Serial ATA International Organization.

It is possible to use standard SATA connectors.

FEATURES

- TDK's proprietary SSD controller LSI GBDriver RS2 series. Compatible with Serial ATA 3Gb/s. High-speed access with a read speed of 95MB/sec.
- 8 or 15 bits/sector error-correcting ability.
- NAND Flash memory control system allows the TDK RS2 series of SSD controllers to achieve high durability against temporary blackouts. By using this together with the power backup circuit inside of the Half-Slim SSDs, cut-off errors can be prevented, and data can thereby be protected. Therefore, these Half-Slim SSDs are highly reliable.
- SLC (Single Level Cell) NAND Flash is used. Highly reliable and durable Half-Slim SSDs with long lifespans.
- TDK's proprietary static wear leveling algorithm levels the frequency of rewriting (erasing) all the areas of the equipped Flash memory and considerably improves the rewriting life of the memory. (As reference, a flash memory with a 16GB capacity can be rewritten (erased) 3.1 billion times. This is equivalent to 10-times rewriting (erasing) per second over a ten year period.)*1
 - *1 For when SLC NAND Flash memory of 4KByte/page structure used. It is also possible to customize the execution range for static wear leveling. In such cases, dynamic wear leveling is used for the execution range outside of static wear leveling.
- "TDK SMART" (SMART: Self-Monitoring & Analysis Reporting Technology) is available from TDK website. TDK SMART information can be downloaded at the following URL. <http://www.tdk.co.jp/memorycontroller/mem01000.htm> This is a lifespan analysis program for understanding the lifespan deterioration of Half-Slim drives using the physical memory level of the NAND Flash memory. For example, by using this lifespan analysis software, it is possible to improve RAS (Reliability, Analysis & Serviceability) monitoring.
- Equipped with a clipping function to set the number of total sectors, which allows customization of the number of logical blocks per sector allotted to the data area. For example, with this function, decreasing the number of logical blocks can increase the possible Half-Slim SSD memory lifespan (rewriting frequency), and for applications that do not need a longer life, increasing the number of logical blocks can maximize the drive capacity. CHS (Cylinder, Head, Sector) parameters of Half-Slim SSDs can also be customized, allowing for easier system implementation such as when replacing TDK Half-Slim drives or when configuring a highly compatible SATA RAID system.*2
 - *2 Settings for the total number of sectors and CHS parameters are optional.
- Advanced encryption functions. AES 128Bit (CBC Mode), which is an advanced encryption standard established by the Federal Information Processing Standard (FIPS) PUB197 of the United States Department of Commerce is used. Data is automatically encrypted and recorded to the memory, which prevents data leakage and falsification.
- Supports security functions based on ATA standards. Customers can set or cancel passwords. By using the AES encryption function, it is possible to prevent unauthorized copying.
- A dedicated FAE (Field Application Engineer) registration system provides customers with registered technical support engineers, and fast and reliable Half-Slim SSD solutions such as for system compatibility verification and customizing.
- These Half-Slim SSDs are RoHS compliant. The components, lead terminals, etc. are all free from hazardous substances prohibited by the RoHS Directives of the EU (European Union).

• Conformity to RoHS Directive: This means that, in conformity with EU Directive 2002/95/EC, lead, cadmium, mercury, hexavalent chromium, and specific bromine-based flame retardants, PBB and PBDE, have not been used, except for exempted applications.

• All specifications are subject to change without notice.

SHAPES AND DIMENSIONS

Half-Slim SATA Half-Slim Solid State Drive SATA

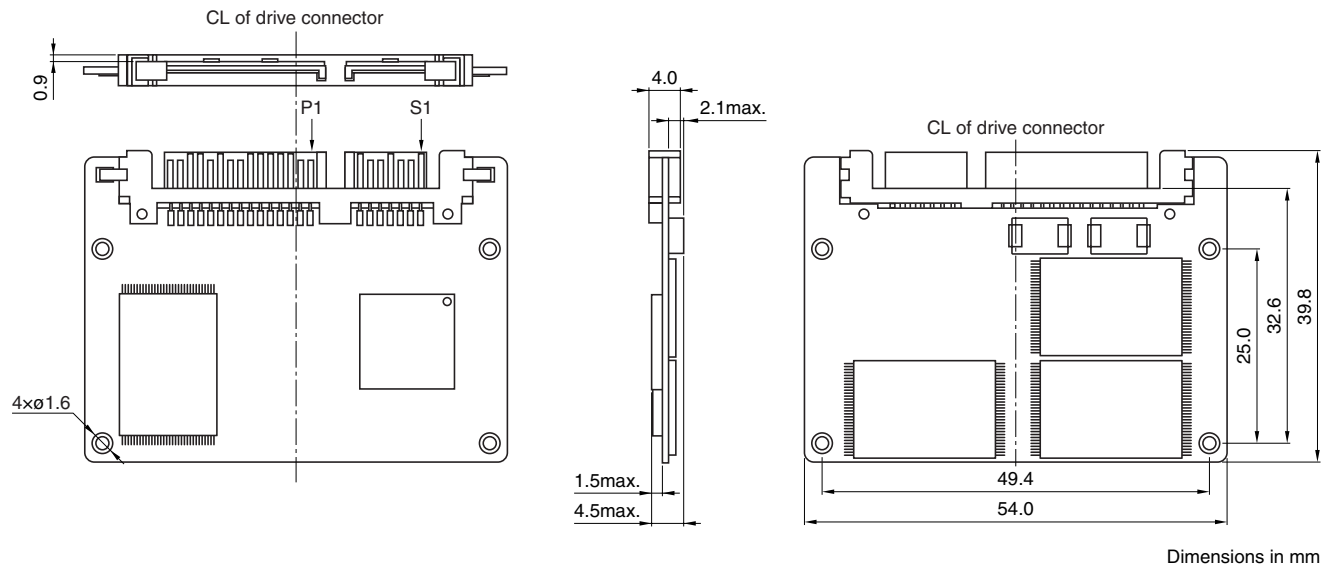

SPECIFICATIONS

Product name	RS2 Series Serial ATA 3Gb/s Interface Half-Slim SSD (Solid State Drive)	
Product No.	SHG2A series	
Data capacity	1GB/2GB/4GB/8GB/16GB	
Size	Half Slim SSD Type SATA	
Memory type	SLC (Single Level Cell) NAND Flash Memory	
Controller	TDK GB Driver RS2a	
Interface	Serial ATA Second Generation	
Transfer mode	SATA Gen1: 1.5Gbps, Gen2: 3.0Gbps	
Transfer speed*	Read(max.)	95MB/s
	Write(max.)	55MB/s
Error-Correcting function(ECC)	8bit/sector (512byte) correction	
Endurance*	Effective blocks×50,000 times (Ex.: 3.1 billion times for 16GB Half-Slim)	
Vibration resistance	15G	
Impact resistance	1,500G(0.5ms)	
MTBF	900,000 hours	
Operating temperature	0 to +70°C[-40 to +85°C industrial option]	
Ambient storage temperature	-25 to +85°C	
Storage/Operation humidity	0 to 90(%) RH [No condensation]	
Power supply voltage	5V±10%	
Acquired standards	CE/FCC/VCCI	
Environmental specifications	RoHS compliant	
Country of origin	Taiwan	

* 4ch Interleaved mode

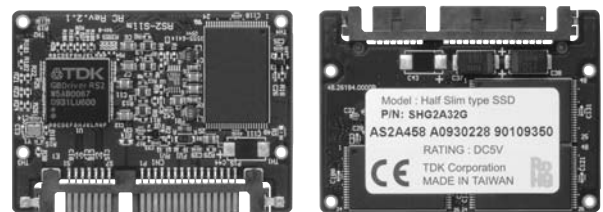

APPLICATION EXAMPLES

- IT equipment such as netbooks, thin clients, tablet computers, and e-book readers.
- Vehicle devices such as car navigation systems, portable navigation devices (PNDs), digital tachographs, ETC equipment, ITS devices, drive recorders, rear-view camera systems, traffic control system devices such as traffic enforcement cameras, and N systems (automatic vehicle number reading devices).
- General OA equipment such as multifunction printers (MFPs), label printers, barcode printers, business use projectors, and electronic blackboards, and DPE photographic development lab equipment.
- Digital photo frames and advertisement display devices such as electronic billboards and electronic POPs.
- Entertainment equipment such as online karaoke, and amusement arcades.
- Energy measurement monitoring systems such as smart meters, power grid communication infrastructure, auto power control systems, and distribution boards, and general smart grid system equipment such as building A/C systems and network devices.
- General FA equipment such as semiconductor manufacturing equipment, NC machine tools, FA robots, mold injection machines, sequencers, PLCs (Programmable Logic Controller), panel computers, box computers, and embedded CPU boards.
- General transportation facility equipment such as automatic ticket vending and checking, and commuter pass-vending machines, train traffic control systems, automatic airline ticketing machines, and automatic check-in machines.
- Financial institution terminals and vending machines such as cash registers and other POS (Point of Sales) equipment, convenient store and kiosk terminals, Felica/Suica terminals, and ATMs.
- General marine navigation equipment such as fish finders, GPS plotters, satellite compasses, Navtex, Navi Net 3D navigation radar, VTS (Vessel Transportation System) devices and overland AIS (Automatic Identification System), Inmarsat, weather FAX machines, National Oceanic and Atmospheric Administration, and Electronic Chart Display and Information Systems (ECDIS).
- General medical equipment, data analysis equipment, and analysis measurement equipment such as ultrasound and X-ray imaging CTs, DNA analysis equipment such as DNA micro array synthesizers and DNA sequencers, blood analyzers, automated biochemical analyzers, medical computers, electronic medical records, electrocardiograms, and remote medical equipment using 3D internet systems.
- General broadcast and wireless information system equipment for communication base stations such as LTE (Super 3G) third-generation mobile phone data communication systems and IP simulcast radios.
- General security terminals and security equipment such as digital signage, biometric authentication systems, entrance control systems, surveillance cameras, security recorders, and security camera facial recognition systems.
- General disaster prevention equipment such as earthquake early warning systems and residential fire alarm devices.

MAIN APPLICATIONS

- Replacing HDDs with SSDs.
- Can be used with HDDs in SATA RAID systems for cloud computing systems.
- OS, system, and user data storage for electrical household appliances such as 3D TVs, Blu-ray Disc players, and digital TVs.
- Equipment requiring high reliability, high durability, and life monitoring functions including replacement time detection such as smart grid systems.
- High-speed booting devices using OS HORM (Hibernate Once/Resume Many) functions for embedded equipment such as Windows XP Embedded.
- Storage devices requiring a high frequency of data writing such as POS systems and inventory management systems.
- Usages requiring vibration resistance, energy conservation, and compact size such as Green IT equipment, medical equipment, logistics systems, machine tools, vehicle devices, and transportation station operation equipment.
- Usages requiring strict data security such as terminals for financial institutions and digital signage.