

# **Gear Tooth Sensors**

For angle/speed sensing

GTS series

Issue date: August 2011

# Gear Tooth Sensors

## GTS Series

This low cost sensor measures the rotation angle of the cam crank. TDK's unique high performance Hall IC manufacturing method provides a sealed sensor in response to the need for automobiles with cleaner exhaust gas, improved fuel consumption, and increased engine performance.

### FEATURES

- Highly precise digital output due to integration of components into an IC package.
- Designed to tolerate extreme temperatures(-30 to +150°C)
- Probe distance can be varied over a wide range.
- Built-in surge voltage suppression circuit.
- Excellent resistance to environmental factors such as vibration, noise, moisture, etc.



### SHAPES AND DIMENSIONS

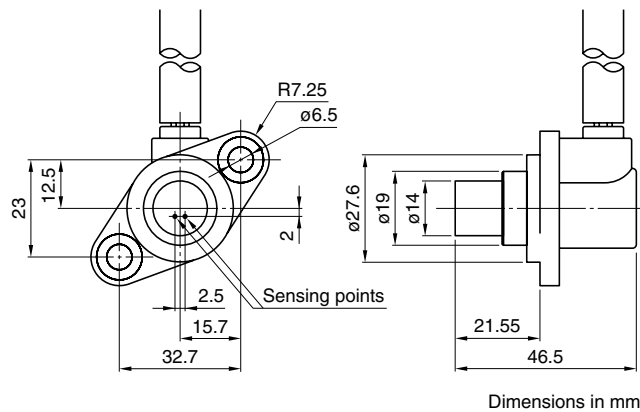

### RATINGS

#### ELECTRICAL CHARACTERISTICS

Operating temperature range	-30 to +150°C
Operating power source voltage	5 to 12V
Output waveform	Open collector
Output voltage	$V_{HIGH} \geq V_{CC} - 0.5V$ $V_{LOW} \leq 0.4V$
Output current	15mA max.
Duty	50±15%(According to gear's shape)
Air gap	1.5mm max.(According to gear's shape)
Response frequency	6Hz to 20kHz

#### EXAMPLE OUTPUT WAVEFORM

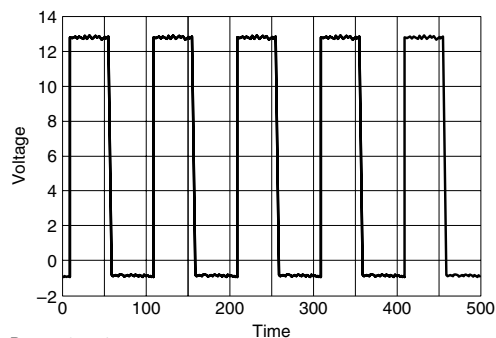

Duty=50±5%  
 $V_{HIGH} \geq V_{CC} - 0.5V$   
 $V_{LOW} \leq 0.4V$   
 Air gap=2mm max.  
 Response frequency=10 to 20kHz

### SENSOR PLACEMENT

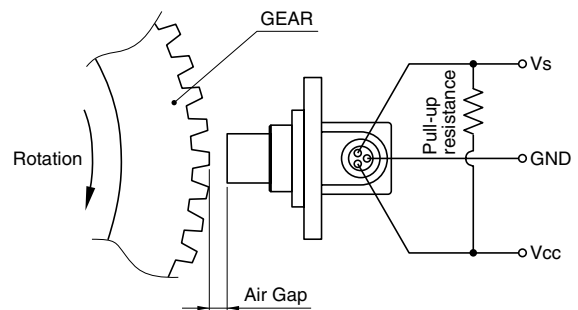

#### RESISTANCE TO ENVIRONMENTAL EFFECTS

Vibration resistance	10 to 500Hz, 20G, 3 directions
Thermal shock resistance	-30 to +150°C, 700 cycles
Resistance to water damage	JIS D S2
High temperature operation	144h in oil bath at 150°C
Low temperature operation	144h in oil bath at -40°C
Overvoltage characteristics	70V, 200000µs/-260V, 2000µs
Resistance to electromagnetic radiation	100V/m, 1 to 200MHz

#### EXAMPLE OF THERMAL CHARACTERISTICS

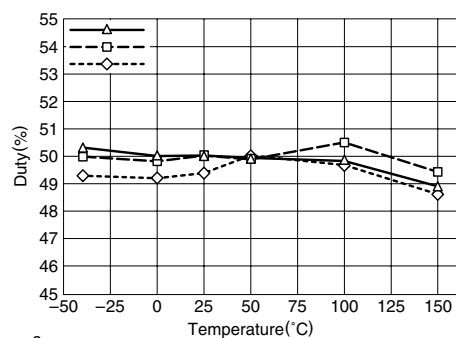

n=3  
 Gear module=2  
 Air gap=1.5mm  
 Rotation speed=50rpm

• All specifications are subject to change without notice.