

DC to DC Converters

Single Output, Non-insulation, 3 to 5.5V Input

Conformity to RoHS Directive

CE-09 Series

SPECIFICATIONS AND STANDARDS

Part No.		CE-0926	CE-0927	CE-0928	CE-0929	CE-0930	CE-0931	CE-0932
Maximum output power	W	1.2	1.2	1.98	0.6	1.5	1.2	1
Input conditions								
Input voltage E _{dc}	V	+3.0 to +5.5	+3.0 to +3.6	+4.5 to +5.5	+3.0 to +5.5	+3.0 to +3.6	+3.0 to +5.5	+3.0 to +5.5
Efficiency (typ.) ^{*1}	%	80	80	88	67	83	83	72
Output characteristics								
Standard output voltage E _{dc}	V	±12.0	+2	+3.3	-2	+5	±15.0	-5
Output voltage setting deviation (max.)	V	—	+1.0 to +2.0	+2.0 to +3.3	-1.8 to -2.5	+4.0 to +5.8	—	-4.0 to -5.5
Maximum output current	mA	50/ch ^{*4}	600	600	300	300	40/ch ^{*4}	200
Maximum output current	%	±5	±4	±4	±4	±4	±4	±5
Output voltage total variation ^{*3}	mV	50	50	50	50	50	50	50
Ripple noise E _p -p (typ.)	mV	100	100	100	100	100	100	100

^{*1} The maximum power value equals the standard output voltage multiplied by the maximum output current.

^{*2} The standard output voltage depends upon each product. The output voltage in the normal condition is distributed over the upper limit side within the output voltage stability range (other than CE-0926, CE-0931).

Output voltage setting method

If there is a difference from the required output voltage, substitute an absolute value of the required output voltage into V_o in one of the following equations to calculate R_{ex} and then install the product between the connected terminals.

Part No.	Terminal No.	Expression
CE-0927	6,7	$R_{ex} = \frac{5.90 \times V_o - 5.95}{2 - V_o}$
CE-0928	6,7	$R_{ex} = \frac{13 \times V_o - 25.56}{3.3 - V_o}$
CE-0929	5,6	$R_{ex} = \frac{34 \times V_o - 61}{2.5 - V_o}$
CE-0930	6,8	$R_{ex} = \frac{46 \times V_o - 183}{5.83 - V_o}$
CE-0932	5,6	$R_{ex} = \frac{98 \times V_o - 389}{5.5 - V_o}$

*Unit: V, kΩ

^{*3} Output voltage total variation (%) is a regulation including a load variation, an input variation, and a temperature variation, compared with the output voltage stability value.

^{*4} The output side (I_{o2}) of the output model should be used within the range of the operating area shown below.

PRECAUTIONS

- When a choke coil is connected between the input-side power supply and the terminal 2, it should be of 4.7μH max. Otherwise, an output ripple may be increased.
- When the input-side power supply has a high ripple voltage or when it is required to reduce the ripple returning from the converter to the input, connect a capacitor having an appropriate capacity.
- To normally start the converter, the rise time of the input voltage must be less than 40ms. In other words, it is required to limit the time to 40ms between the time points of exceeding a 0.5V input voltage and going-up to the predetermined input voltage range.
- Parallel operation to increase output current is not possible.
- Cleaning of this product is inhibited.
- Less-residue or non-cleaning type flux should be used so as to omit the cleaning.

CE-0926

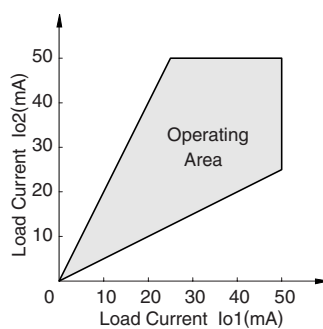

CE-0931

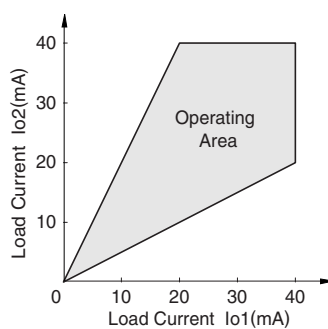

• Conformity to RoHS Directive: This means that, in conformity with EU Directive 2002/95/EC, lead, cadmium, mercury, hexavalent chromium, and specific bromine-based flame retardants, PBB and PBDE, have not been used, except for exempted applications.

• All specifications are subject to change without notice.

SHAPES AND DIMENSIONS

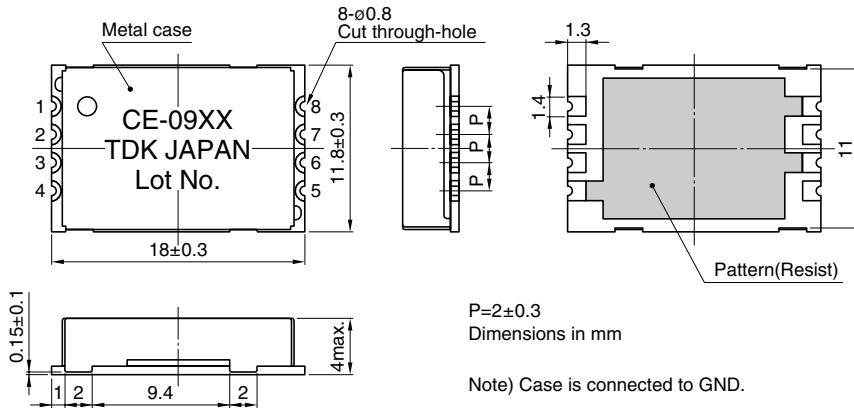

LAND DIMENSIONS(REFERENCE)

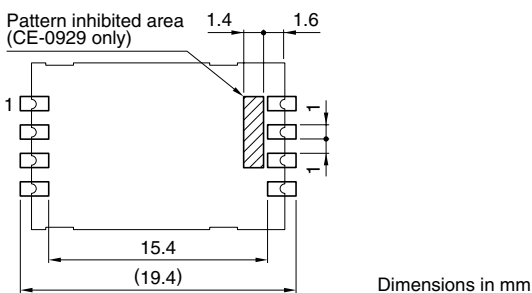

TERMINAL CONNECTION

No.	CE-0926	CE-0927	CE-0928	CE-0929	CE-0930	CE-0931	CE-0932
1	GND	GND	GND	GND	GND	GND	GND
2	Vin	Vin	Vin	Vin	Vin	Vin	Vin
3	GND	GND	GND	GND	GND	GND	GND
4	N.C.	N.C.	N.C.	N.C.	N.C.	N.C.	N.C.
5	GND	GND	GND	GND	GND	GND	GND
6	N.C.	Vo-adj.	Vo-adj.	Vo-adj.	Vo-adj.	N.C.	Vo-adj.
7	-Vo	+Vo	+Vo	-Vo	N.C.	-Vo	-Vo
8	+Vo	+Vo	+Vo	N.C.	+Vo	+Vo	N.C.

- While the terminals 1, 3, and 5 are internally-common GND terminals, the terminal 3 should be used for the input-side GND and the terminal 5 should be used for the output-side GND, as much as possible (or they should be for a plain GND terminal). The terminal 1 should not always be connected to a GND.

COMMON SPECIFICATIONS

Auxiliary functions	
Output voltage setting function	Yes(Except CE-0926 and CE-0931)
Overcurrent protection	No
Constructions	
External dimensions	mm 18 \times 4 \times 11.8(W \times H \times D)
Weight	g 1.5
Temperature and humidity	
Operating temperature range	$^{\circ}$ C -40 to +85
Storage temperature range	$^{\circ}$ C -40 to +85
Operating humidity range	(%)RH 10 to 95[Maximum wet-bulb temperature: 38 $^{\circ}$ C]
Storage humidity range	(%)RH
Amplitude and vibration	
Amplitude	10 to 2000Hz, 4min/cycle, 10G, 3 directions each 30min
Vibration	100G, 6ms, 6 directions, each 3 times

CIRCUIT DIAGRAMS

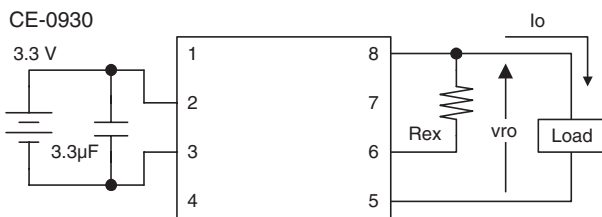
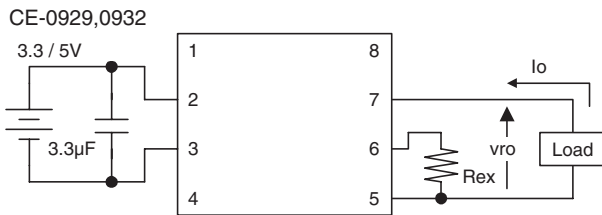
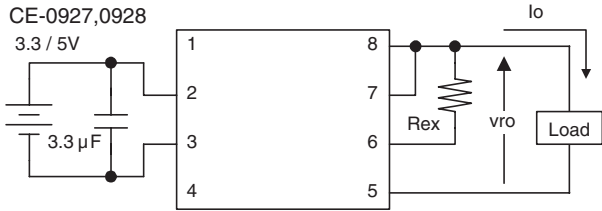
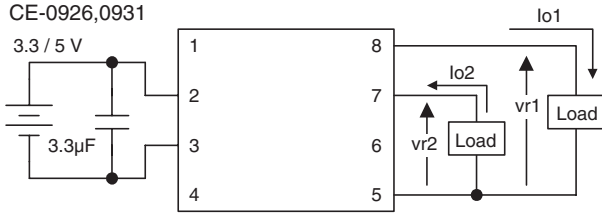

RECOMMENDED REFLOW SOLDERING CONDITIONS

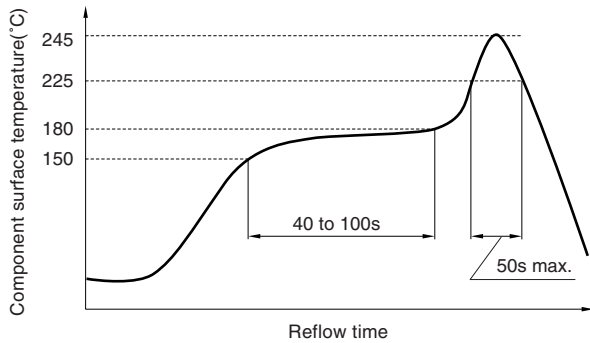

Peak temperature: 245°C max.
 Reflow temperature: over 225°C, 50s min.
 Preheating temperature: 150 to 180°C, 100s min.

PACKAGING STYLE AND QUANTITY

There are two packaging styles of separate product and taping product.
 The part No. of the taping product ends with -TP.
 Example: CE-0931-TP

TAPING SPECIFICATIONS

Carrier tape dimensions

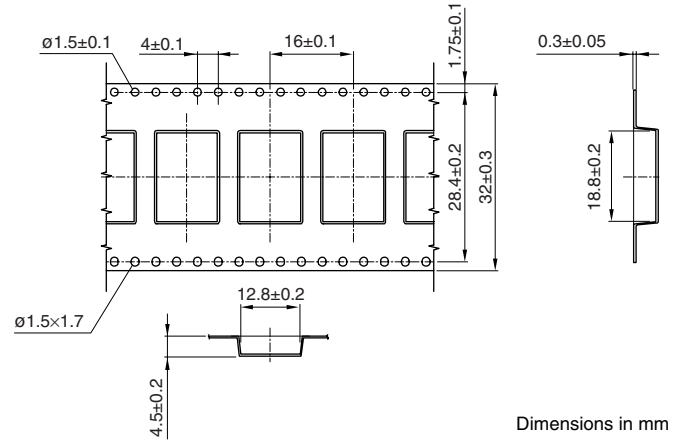

Reel dimensions

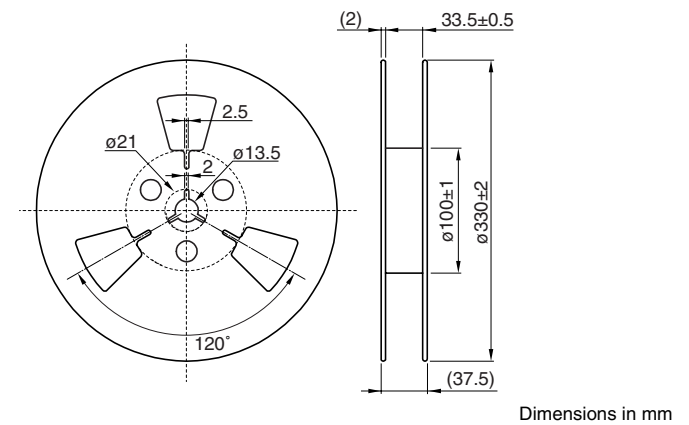

TAPING DIRECTION

View from cover tape

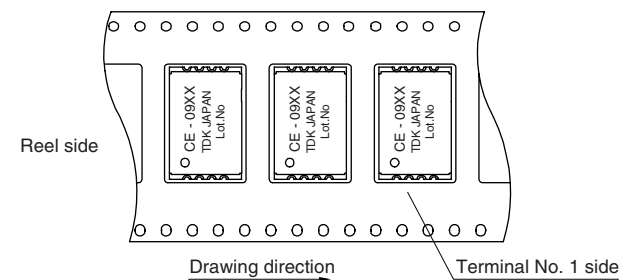

PACKAGE QUANTITY

500 pieces per reel
 Maximum 3 reels are packed in a reel box.
 The following items are indicated on the packing box:

1. Part No.
2. Quantity
3. Lot No. or manufacturing date
4. Name of manufacturing company

• All specifications are subject to change without notice.